

MDX-R3 FOR ADJUSTABLE CONCRETE POOLS OWNER'S MANUAL AND INSTALLATION GUIDE - AUSTRALIA

SUBMERGED SUCTION OUTLET FOR MULTIPLE DRAIN USE FOR USE ON FLOOR



VGB Compliant ANSI/APSP/ICC-16 2017 LISTED

NOTICE

When installing and using this equipment, basic safety precautions shall always be followed, including the following:

**IMPORTANT SAFETY INSTRUCTIONS.
TO INSTALLERS: READ, UNDERSTAND,
AND FOLLOW ALL INSTRUCTIONS AND
WARNINGS.**

Give these instructions to the facility owner to keep for future reference. Follow all codes and regulations that apply to the design, installation and use of suction outlet fittings.



WARNING

MDX-R3 and SDX2 must be installed in accordance with Paramount's written instruction manual, and in conformity with applicable Federal, State, Local and Swimming pool industry building and safety codes.

Any modification that increases the flow rate of the circulation system shall require reevaluation of the cover/grate and sump to ensure that the flow rating of the Suction Outlet Fitting Assembly (SOFA) is not exceeded.

Certificate of conformity available at

<https://www.1paramount.com/downloads/manuals/mdxr3/MDXR3CertificateOfConformity.pdf>

SAVE THESE INSTRUCTIONS



8175 W. Buckeye Rd., Phoenix, AZ 85043
Toll Free: 1.800.621.5886 • Phone: 480.893.7607 • Fax: 480.753.3397
Paramount@1Paramount.com • www.1Paramount.com
US and Foreign patents and patents pending
see www.1paramount.com/support/patent-numbers/

Signal Words and Symbols Used In This Manual

This Owner's Manual and Installation Guide contains specific precautions and symbols to identify safety-related information. You will find DANGER, CAUTION, WARNING and NOTICE symbols which require special attention. Please read them carefully and follow these precautions as indicated! They will explain how to avoid hazards that may endanger you or persons using or maintaining your pool or spa.



DANGER

DANGER indicates a hazardous situation which, if not avoided, will result in death or serious injury.



WARNING

WARNING indicates a hazardous situation which, if not avoided, could result in death or serious injury.



CAUTION

CAUTION indicates a hazardous situation which, if not avoided, could result in minor or moderate injury.

NOTICE

NOTICE is used to address practices not related to physical injury.

PLEASE REVIEW THE OWNER'S MANUAL AND INSTALLATION GUIDE IN ITS ENTIRETY AND HEED ALL SAFETY INFORMATION. Failure to follow these instructions and warnings can result in DEATH OR SERIOUS INJURY.

SUCTION ENTRAPMENT HAZARD:



DANGER

• **DEATH or SERIOUS INJURY will result if a drain cover or grate is not installed and used correctly.**

- Pool and spa pumps produce high levels of suction and move high volumes of water, which can cause death or serious injury if a person comes in close proximity to pool or spa drains.
- SOFA shall not be located on seats or the back rests for seats
- Any modification that increases the flow rate of the circulation system shall require reevaluation of the cover/grate and sump to ensure that the flow rating of the Suction Outlet Fitting Assembly (SOFA) is not exceeded.
- Keep clear of pool and spa drains to avoid death or serious injury from suction.



DANGER

DEATH or SERIOUS INJURY will result from hair entanglement or limb entrapment.



- Keep clear of pool and spa drains.
- Hair sucked into pool or spa drains will tangle and knot trapping the swimmer underwater. Avoid placing your hair near a pool or spa drain.
- Avoid sitting on pool or spa drains because the suction can cause severe intestinal damage, evisceration, and/or disembowelment.



DANGER

DEATH or SERIOUS INJURY will result from pool or spa drain covers or grates that are improperly installed, missing, clogged, or broken.

- Inspect pool and spa before each use to ensure that drain covers and grates are properly in place and secured.
- Ensure that drain covers are not damaged, cracked, broken, loose, clogged, not properly secured, or missing because these conditions increase the chance of death or serious injury from entrapment.
- If a drain cover is discovered damaged, cracked, broken, loose, clogged, not properly secured, or missing, you shall:
 - Close the pool or spa immediately; and,
 - Post a closure notice and keep the pool or spa closed until an appropriate ANSI/APSP/ICC-16 2017 certified drain cover is properly installed.
- Missing, broken, or cracked SOFA component shall be replaced before bathers are allowed to use the pool.
- Loose cover/grates shall be reattached before bathers are allowed to use the pool.

DANGER



- **DEATH or SERIOUS INJURY** will result from contact with a damaged, loose, or missing drain cover.
- Do not allow limbs to contact or be inserted into a drain pipe with a damaged, loose, or missing drain cover. This could result in swelling of the limb and/or trapping a swimmer underwater.
- Avoid mechanical entrapment of jewelry, swimsuit, hair decorations, finger, toe, or knuckle in a drain pipe with damaged, loose, or missing drain cover. This may result in trapping a swimmer underwater.
- Do not allow body to come into contact with a drain pipe that has a damaged, loose, or missing drain cover. This may result in trapping a swimmer underwater.

MAINTENANCE INSTRUCTIONS & WARNINGS:

WARNING

DEATH or SERIOUS INJURY can result from pool or spa drain covers or grates that are clogged by debris.

- Any field modification made to a SOFA not authorized by the manufacturer's instructions shall void the SOFA certification.
- No modification shall be made to the SOFA structure or flow path unless the new configuration has been certified as a new SOFA.
- All pool and spa drain covers may become obstructed by debris and should be cleaned periodically due to clogging from debris, such as pieces of plastic, hair, fabric, twigs, leaves, seeds, etc.
- The frequency of periodic cleaning will vary depending on the amount and type of debris introduced into the pool or spa
- Clogging of the drain cover will increase the suction effect and increase the likelihood of death or serious injury from those hazards listed above.
- A clogged drain can negatively affect the safety of the drain.
- It is advisable to have a qualified pool or spa professional perform this inspection and debris removal from the pool and spa drain covers.
- When servicing the drain cover, the pump connected to the suction must be turned off.
- Do not perform any service of the drain cover in water level above your waist.
- Use drain covers only with a pumping system rated for the corresponding flow or less. Failure to do so can result in hair or body entrapment which can cause death or serious injury. If in doubt about the rating of your system, consult a qualified pool or spa professional.
- Use only the supplied stainless-steel screws with the drain cover. Screws put into the frame anywhere except in the original screw holes will not hold and will allow the drain cover to come off the main drain, causing an entrapment hazard. If a screw hole(s) is stripped, inserts missing, loose, or damaged, consult your owner's manual and installation guide for proper steps to replace, correct, or reattach the compromised drain or drain component.
- The use of adhesives or other attachment methods that prevent access to suction piping or SOFA components requiring periodic service is prohibited.

WARNING

Suction can pose a serious hazard to swimmers just as electricity can be a hazard. Both are important for proper water filtration and both must be treated with respect. Suction safety begins with a professional design that includes a

quality suction system installed by a certified contractor.

- Certified builders will address the following issues when designing and installing a proper filtration system:
- Properly bond-grounded pumps, time clocks, switches and any other metal in or near water. This is required to address Electrical Shock Hazards.
 - Design the suction piping so there are no single-point suction hazards; single-point suction (one drain) is a leading cause of Body Suction Entrapment Hazards. Note: your certified builder has many effective options for addressing this hazard; they may include dual-drain systems, like MDX-R3, skimmers, gutters, negative edge features and many more products and piping designs known to professionals.
 - Install ANSI/APSP/ICC-16 2017 listed drains, suction covers and debris removal systems. This is the ONLY approved option for preventing Hair Entrapment Hazards, the leading cause of suction related injuries.
 - Design and install an effective circulation system (including optional cleaning systems), to direct filtered water to all areas and interior surfaces. NOTE: Suction fittings can NOT clean or direct filtered water for proper sanitation; that can only be done on the pressure (return) side of the filtration system.

While suction injuries are extremely rare, drowning and diving injuries are far too common and there is little your certified builder can do to eliminate these hazards. You must educate yourself and your guests. Below are some important safety issues every swimmer must know and recognize.

- **PREVENT DROWNING:** Watch children at all times, no swimming alone.
- **NO DIVING IN SHALLOW WATER:** You can be permanently injured.
- **PREVENT SUCTION ENTRAPMENT:** Inspect suction covers before swimming, keep swimmers away from suction fittings, protect long hair, don't swim with loose clothing or large and dangling jewelry.

For more information about the Virginia Graeme Baker Pool and Spa Safety Act, contact the Consumer Product Safety Commission at (301) 504-7908 or visit www.cpsc.gov.

WARNING

Always turn off all power to the pool pump before installing the cover or working on any suction outlet.

- Cover/Grates and all other SOFA components shall be replaced at or before the end of their service life. Service life begins the month and year in which the SOFA is installed with or without water. See parts breakdown at end of this manual for specific component service life notations.
- Any SOFA component that is severely faded, chalking, or brittle when flexed shall be replaced even if it has not reached its indicated service life.
- If the sump/mud ring or any screw receptacle is stripped, cracked or broken that component must be replaced.
- Any SOFA component held in place by the pool finish or concrete substrate that becomes cracked or broken; the material that holds it must be stripped from around the SOFA and new components "mudded" in place. The surface substrate must be free of deterioration and voids.

ADHERE REPLACE COVER ASSEMBLY STICKER TO THIS PAGE

**Adhere this label to page 4 of the installation manual.
Must mark year and month of installation**

Paramount

8175 W. Buckeye Rd., Phoenix, AZ 85043
1-800-621-5886 • 1paramount.com

Replace cover assembly within (5) five years.

Replace all other components within (25) years.

MDX-R3 pool floor drain cover part #005-252-8243-XX
Maximum GPM = 132 (500 LPM)
Circle year and month of installation.

Year	2021	2022	2023	2024	2025							
Month	01	02	03	04	05	06	07	08	09	10	11	12

System flow rate _____

Installed location _____

001-025-8818-00 ECN 2034 REV02 PUB 042221
©2021 Hayward Industries, Inc.

MDX-R3 SYSTEM DESIGN

These MDX-R3 instructions provide two methods to choose from, with additional methods for specific jurisdictions, (California specifically but not limited to that state). Your local codes may require additional safety measures. Paramount Pool & Spa Systems and its representatives cannot recommend or endorse installation methods other than those provided in these MDX-R3 instructions.

MDXR3 is a blockable SOFA and must be installed only as a multiple SOFA system as described in this installation manual.

WARNING

Maximum Pump Size:

MDX-R3 is rated for a maximum of 132 GPM (500 LPM). While system flow rate will vary with pump size and the Total Head Loss for a given system, virtually any modern pump is capable of exceeding this limit, therefore it is the responsibility of the system designer to make sure it is not possible to exceed 132 GPM (500 LPM). This VGBA Suction outlet has an installation specific flow rating and this product SHALL NOT be installed on a pumping system that is capable of exceeding this limit, which varies based on the number and location of installed suction outlets. READ and FOLLOW the section of the included installation instructions explaining how to calculate the suction system flow ratings and that of the installed pumping system.

In the event of one suction outlet being completely blocked, the remaining suction outlets serving that system shall have a flow rating capable of the full flow of the pump(s) for the specific suction system.

NOTICE

The use of two 45° in place of a 90° allows for the best debris removal and minimizes large debris from getting caught in the line.

NOTICE

Plumbing of the included enlarged suction element to the 4" port of the MDX-R3 is required. After the enlarged suction element, a reducer may then be used to reduce the pipe size to 2½".

A 3" pipe may be attached to the inside diameter of the enlarged suction element or a 4" x 13" minimum length pipe directly to the drain socket for systems where the flow through the MDX-R3 is intended to exceed 90 GPM. **Use of 2½" pipe minimum throughout the suction side of the system is strongly encouraged for optimum performance.** For your convenience, Paramount Pool & Spa Systems includes the single piece enlarged suction element or the reducer adapter and enlarged suction element with the MDX-R3. To order separately, please see parts page for the part number.

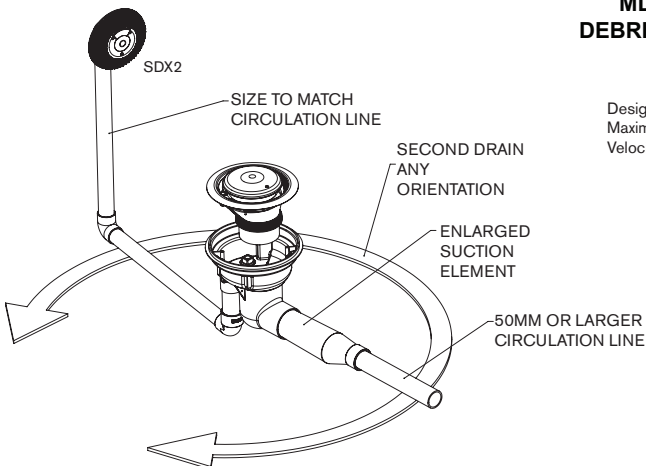

MDX-R3 VGB COMPLIANT DEBRIS DRAIN STANDARD POOL DESIGN, AUSTRALIA DUAL DRAIN

Design Flow Rate = 132 GPM (500 LPM)
Maximum GPM (LPM) = 132 (500)
Velocity at 132 GPM = 1.294 FPS (.39 MPS)

NOTICE

Velocity in suction plumbing must be designed to not exceed 6 ft./sec. per APSP-7-2006.

FLOW HEAD LOSS CURVE

HEAD LOSS CURVE MDX-R3

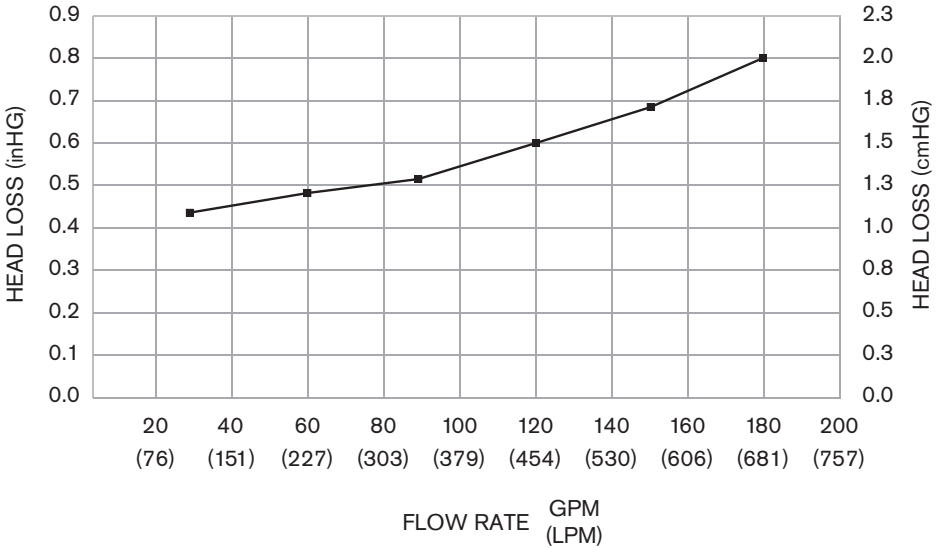

MDX-R3 INSTALLATION WITHOUT SKIMMER INSTALLED

WITH CANISTER

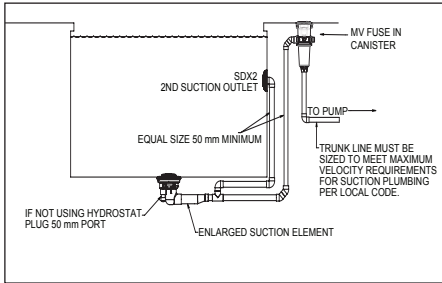

*Note: Canister requires 40 mm equalizer line through pool wall. (Not Shown)

WITHOUT CANISTER

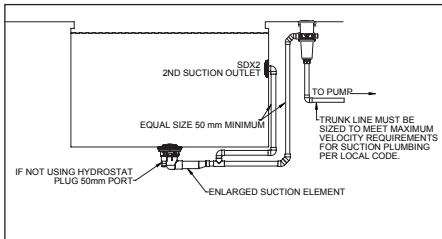
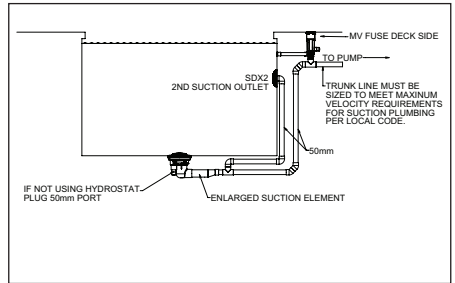

*Note: Canister requires 40 mm equalizer line through pool wall. (Not Shown)

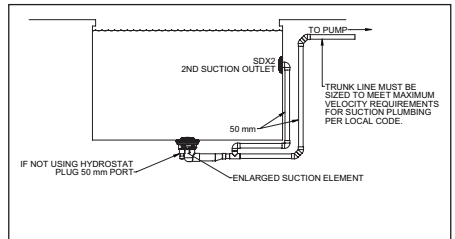

MDX-R3 INSTALLATION METHOD 1 - SINGLE MDX-R3

WITH CANISTER

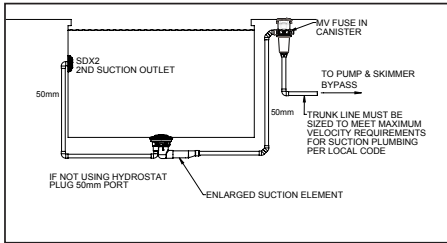

WITHOUT CANISTER

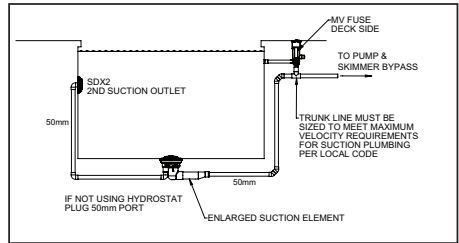

*Note: Canister requires 40mm equalizer line through pool wall. (Not Shown)

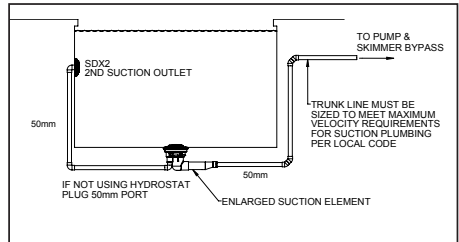
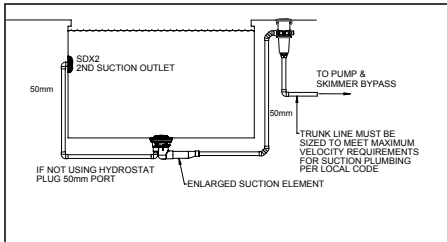

*Note: Canister requires 40mm equalizer line through pool wall. (Not Shown)

MDX-R3 PLUMBING

MDX-R3 Plumbing (Fig. 1)

1. Position the top edge of the MDX-R3 sump 1" below the finished depth of the pool, spa, or a basin (Fig. 1). Finish concrete to top edge of construction cap. Orientate the sump so the elbow is perpendicular to inside wall or end wall of pool.
2. Position the REQUIRED SDX2 High Flow Safety Drain® on a sidewall of the pool below water level (if pool will be winterized, place it high enough to reach from the deck). Option: The SDX2 High Flow Safety Drain may be positioned on the floor a MINIMUM of three (3) feet away from any other Suction Outlet.

Fig. 1

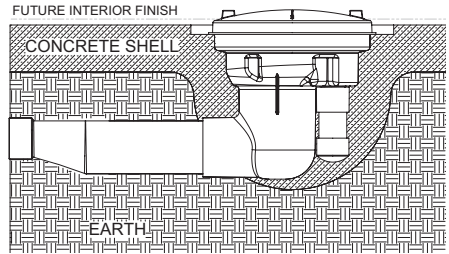

HYDROSTATIC FITTING

The hydrostatic port inside the MDX-R3 Sump is equivalent to a 2" Threaded Female Adapter and a 2" Slip Fitting Outside the MDX-R3 Sump. This port is for the purpose of a hydrostat only. Paramount recommends the use of the 2" thread plug provided. Do not use check valves here that are prone to sticking open causing the need to open the drain cover exposing a suction risk. If a hydrostat is not used, plug this port from bottom with pipe and cap. Do not install any suction equipment (pump) to this port!

MDX-R3 PRESSURE TESTING

Pressure Test-READ BEFORE INSTALLATION: New Style Test Plug

The 4" pressure test plugs (005-252-1610-00) use an o-ring to make the seal.

Wrap once with Teflon tape to prevent plastic threads from binding. Insert plug into threaded socket. Use an adjustable wrench, a 1 1/2" 12 pt socket or pliers on lug and tighten by hand until snug. Over tightening may cause parts to break.

Pressure should remain on the system through construction until interior cleanup.

Fig. 2

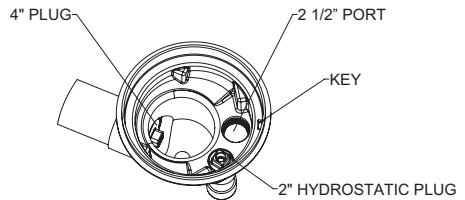

WARNING

Release pressure on the system before removing plugs

SDX2 CONCRETE INSTALLATION

The SDX2 High Flow Safety Drain® installed in a concrete shell utilizes a small cutout in the concrete to form the sump which is sometimes made of plastic or fiberglass. This concrete sump provides superior shell strength by eliminating the large hole associated with plastic sumps. The water seal is formed against the suction pipe in the same way a water tight seal is formed with return pipes. The concrete cutout is typically 280mm (280mm) wide, by 50mm (2") deep, with a finger size cutout around the pipe to allow room for a watertight seal. (Fig. 3)

Rebar Steel (Fig. 5)

Concrete reinforcing steel should be kept 75mm away from all pipe and fittings.

Concrete Shell Sump (Fig. 3)

Form a concrete sump around each suction pipe.

Concrete Shell Preparation (Fig. 4)

Prior to installing the interior finish, cut each SDX2 riser pipe approximately 25mm behind the concrete shell's surface.

NOTICE

Suction Safety Standards require that main drain grates used to cover concrete sumps, must have the suction pipe cut at least 1 1/2 times the pipe diameter behind the drain cover. This is to allow room for even water flow through all drain cover holes. This is not necessary with the SDX2 drain because the Patented Design provides uniform suction regardless of pipe location. However, if the pipe is too close to the surface, it may restrict water flow to the pump, reducing hydraulic efficiency, but this does not pose a suction safety hazard.

Fig. 3

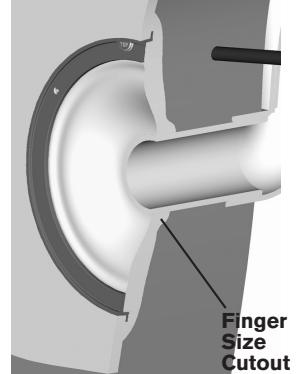
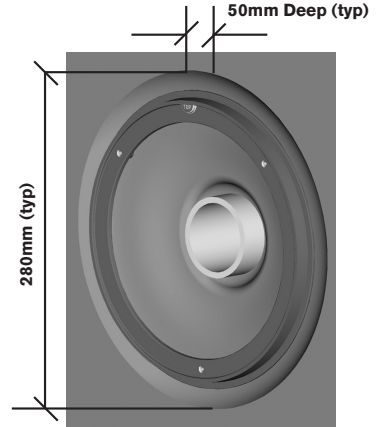
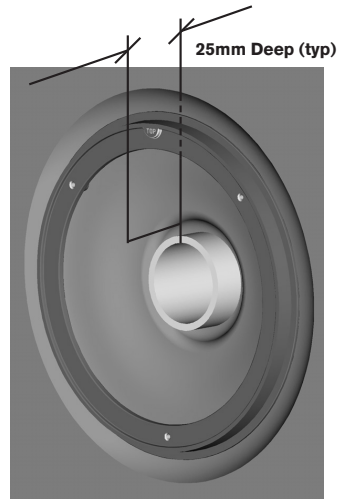

Fig. 4



NOTICE

DO NOT USE POWER TOOLS TO INSTALL FASTENERS. Start all fasteners by hand to prevent cross threading.

Concrete Ring Installation (Fig. 5)

1. Apply interior finishing material.
2. Position the SDX2 Concrete Ring with the semi-circle tab located at the top and then press the ring into finishing material.
3. Trowel the finishing material around outside and inside of the SDX2 Concrete Ring.
4. Form a watertight seal around the suction pipe.
5. Wipe clean any finishing material that remains on the SDX2 Concrete Ring's top edge and mounting surface.

Fig. 5

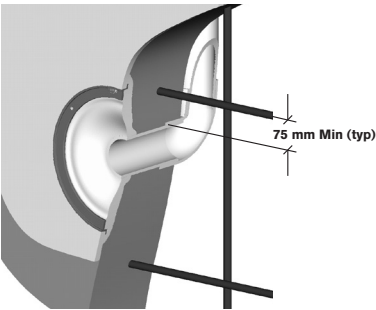

Concrete Cover Assembly (Fig. 6)

1. Align the SDX2 Concrete Support with the alignment tab located on the SDX2 Concrete Ring.
2. SOFA components and fastener receptacles shall be clean and free of debris and obstruction during installation of cover/grate fasteners.
3. Install three (3) machine screws through the SDX2 Concrete Support. Secure the screws without over tightening to 18 in-lbs.
4. Align the SDX2 Cover with the SDX2 Support holes.
5. Install three (3) security screws through the SDX2 cover. Secure screws to (14 in-lbs)
6. After securing each SOFA component hand check that it is snug to the sump /frame before proceeding to the next component.

Fig. 6

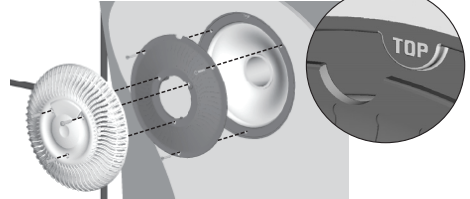

STEEL AND CONCRETE INSTRUCTIONS

Keep rebar 75mm away from MDX-R3 sump. (Fig. 7)

1. To allow the sump to be fully encased in concrete, clear dirt to completely expose the sweep elbow. (Fig. 8)
2. Pack concrete around and under sump (Fig. 8) to ensure seal and strength of shell
3. Angle shell down to MDX-R3 sump. (Fig. 8)
4. Make cut-out around MDX-R3 sump. 440mm round by 19mm deep to water stop down . (Fig. 9 & 11)

Fig. 7 MDX-R3 VGB COMPLIANT DEBRIS DRAIN STANDARD POOL/SPA/BASIN DESIGN STEEL CAGE

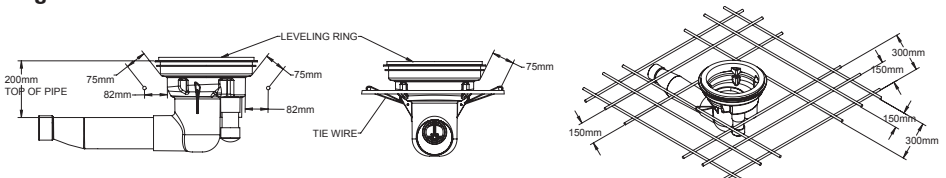

Fig. 8

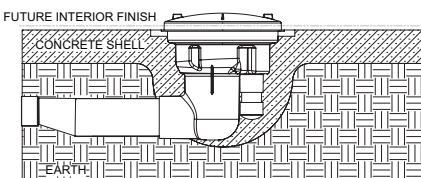

Fig. 9

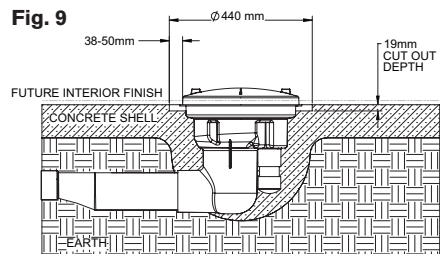

Fig. 8

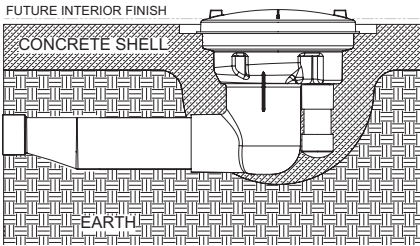
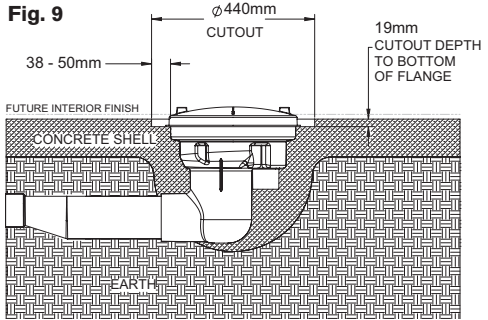

Fig. 9



Plaster Ring Installation:

The Concrete Ring should be attached to the MDX-R3 Sump prior to finishing the interior surface of the pool, spa, or basin.

1. Remove all plugs before starting final finish application. Use an adjustable wrench or pliers to remove 4" plug. Set the leveling ring at final finish.
2. Align the Leveling Ring Keyway with the Sump Alignment Key. (Fig. 10)
3. Adjust the elevation and the angle of the Leveling Ring to align it with the finished interior surface of the pool, spa, or basin.
4. Use a sealing compound compatible with the interior surface to lock the Concrete Ring in place and to provide a water-tight seal.

*Sealing compound example: Topping Mix Cement, hydraulic cement, and Thoro Acryl®60 by ChemRex® or equivalent.

Assemble the drain PRIOR TO ADDING WATER

NOTICE

DO NOT USE POWER TOOLS TO INSTALL FASTENERS. Start all fasteners by hand to prevent cross threading. Cover/grate when installed shall not protrude more than 2" (51mm) from the finish surface of the pool in which the SOFA is installed.

1. Remove 4" pressure plug.
2. SOFA components and fastener receptacles shall be clean and free of debris and obstruction during installation of cover/grate fasteners.
3. Install funnel assembly (#3) onto leveling ring (#5) and secure with 4 (four) security screws (#2) with screw driver security T25 (#15). Secure self-threading screws to 14 in-lbs on initial install and 10 in-lbs for subsequent insertions.
4. Install the cover (#1) onto the funnel assembly (#3) and secure with 3 (three) security screws (#2). Secure self-threading screws to 34 in-lbs on initial install and 20 in-lbs for subsequent insertions.
5. After securing each SOFA component hand check that it is snug in the sump /frame before proceeding to the next component.

Fig. 10

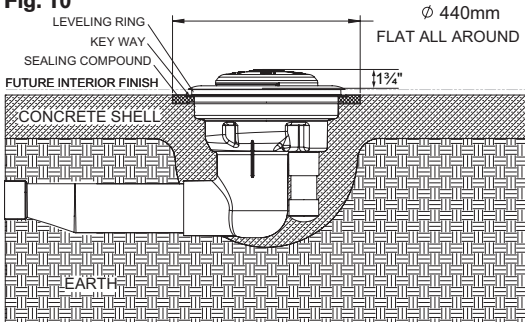
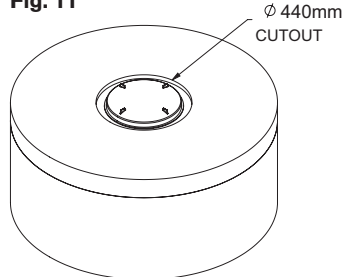
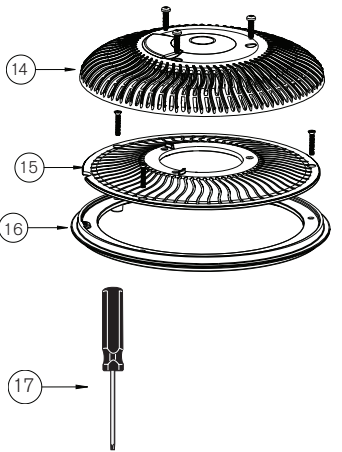
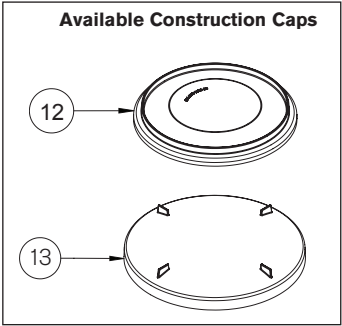
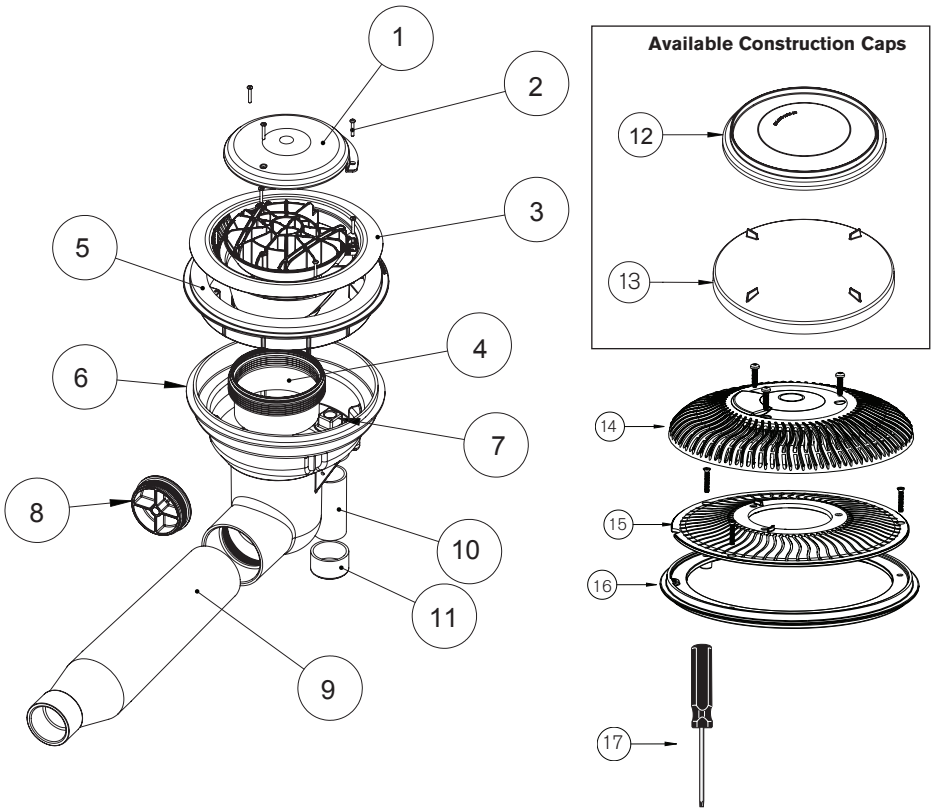

Fig. 11



****Replace cover within 05 installed years. ***Replace all other components within 25 installed years**

MDX-R3 WITH SDX2 FOR CONCRETE POOLS



Item	Part Number	Description
**1	005-252-2110-XX	Cover (XX = Color Code)
**2	005-262-0840-00	Screw Pack (7pcs) 316 SS
**3	005-252-8234-XX	Funnel Assembly
**4	005-252-1045-00	Funnel Adapter
***5	005-262-2045-00	Leveling Ring
***6	004-262-2028-00	Sump
7	005-252-1605-00	2" Plug NPT (6pcs)
8	005-252-1610-00	4" Plug with O-Ring
9	005-252-2540-00	Enlarged Suction Element
*10		2" Pipe - Not Included - Cap If Not Used
*11		2" Cap - Not Included - Cap If Not Used
*12	005-262-1153-00	Plaster Cap
13	005-262-1150-00	Sump Construction Cap
**14	004-162-2213-XX	SDX2 High Flow Safety Drain
**15	005-252-2066-00	SDX2 Support Concrete
***16	005-252-2050-00	SDX2 Ring Concrete
17	005-252-0895-00	T25 Security Screwdriver

* Not part of MDX-R3