

Ultra UV₂

Ultraviolet Water Treatment Device

Owner's Manual

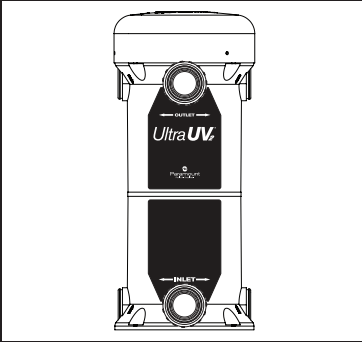

Contents

Safety Instructions.....1
 Introduction.....3
 Installation.....4
 System Start-Up.....10
 Maintenance.....12
 FAQs.....16
 Troubleshooting.....17
 Replacement Parts.....21

	Plug In 120V Models	Hard Wired 120/230V Models
1 Lamp	004-422-2021-00	004-422-2025-00
2 Lamps	004-422-2022-00	004-422-2026-00
3 Lamps	004-422-2023-00	004-422-2027-00



Pool and Spa Water
Treatment Equipment 4BJ1

Paramount
8175 W. Buckeye Rd.,
Phoenix, AZ 85043
Phone: 1-800-621-5886
www.1Paramount.com

Important Safety Instructions



READ AND FOLLOW ALL INSTRUCTIONS

This Owner's Manual contains specific precautions and symbols to identify safety related information as described below. Please read them carefully and follow these precautions as indicated!

⚠ DANGER - Indicates a hazardous situation which, if not avoided, will result in death or serious injury.

⚠ WARNING - Indicates a hazardous situation which, if not avoided, could result in death or serious injury.

⚠ CAUTION - Indicates a hazardous situation which, if not avoided, could result in minor or moderate injury.

NOTICE - Is used to address practices not related to physical injury.

⚠ WARNING - When using this electrical equipment, basic safety precautions should always be followed, including the following:

- Follow all applicable electrical codes.
- Turn off power at main source before making any electrical connections or servicing the unit.
- To reduce risk of electric shock, injury or death disconnect unit from power supply
- Follow the instructions or risk of serious injury or death could occur!
- To reduce risk of injury, do not permit children to use this product unless they are closely supervised at all times.
- Risk of electric shock. Install at least 5 feet (1.5m) from inside wall of pool, hot tub or spa using nonmetallic plumbing.
- This product shall only be connected to a power supply receptacle protected by a ground fault circuit interrupter.

⚠ WARNING - UV EXPOSURE & PROTECTION: UV-A and UV-B radiation can have adverse short and long term effects on the eyes and skin. Never look directly at a UV lamp that is connected to a power source. Avoid UV skin exposure at all times.

DANGER - RISK OF INJURY: (a) Replace damaged cord immediately. (b) Do not bury cord. (c) Connect to a grounded, grounding type receptacle only.

PLEASE REVIEW THE OWNER'S MANUAL IN ITS ENTIRETY AND HEED ALL SAFETY INFORMATION. FAILURE TO FOLLOW THESE INSTRUCTIONS AND WARNINGS CAN RESULT IN DEATH OR SERIOUS INJURY.

SAVE THESE INSTRUCTIONS



Paramount

Table of Contents

Important Safety Instructions	1
Introduction	3
General Product Information.....	3
Ultra UV ₂ System Sizing.....	3
Installation	4
Locating The Ultra UV ₂ Unit.....	4
Mounting the UV Unit on a Solid Base.....	5
Installing Inlet/Outlet Unions.....	5
Plumbing The Ultra UV ₂ Unit.....	5
Typical Plumbing With and Without Bypass.....	6
Parallel Plumbing With and Without Bypass.....	7
Mutiple Port Plumbing for 3 Lamp Units With and Without Bypass.....	7
Electrical Wiring.....	8
Plug In 120V 50/60Hz Ultra UV ₂ Units.....	8
Hard Wired 120/230V 50/60Hz Ultra UV ₂ Units.....	9
Electrical Bonding.....	9
System Start-Up	10
Pressure Switch.....	10
Water Chemical Balance.....	10
Normal Operation.....	11
Winterize/Service Operation.....	11
Maintenance	12
Winterization of Your Ultra UV ₂ Unit.....	12
Quartz Tube Maintenance.....	13
Scheduled UV Lamp(s) Replacement.....	15
FAQs	16
Troubleshooting	17
Identifying and Correcting System Problems.....	17
Specification Notice.....	19
Limited Warranty.....	19
Head Loss Curves.....	20
Replacement Parts	21

Introduction

⚠ WARNING - The Ultra UV₂ unit is designed for use in swimming pools, spas, fountains, water features, waterfalls, fish ponds and the like. IT IS NOT DESIGNED FOR USE IN POTABLE (DRINKING) WATER INSTALLATIONS. Use of this product in applications other than those indicated above will void your warranty and could be harmful to your health or the health of others.

General Product Information

Water circulates through the Ultra UV₂ chamber and around the quartz tube where the UV-C lamp(s) (1 to 3 lamps depending on the model) are housed. Refer to the table below to determine the Ultra UV₂ Part Number needed for your application. **Please note the minimum and maximum flow rates for each Ultra UV₂ lamp configuration.**

⚠ CAUTION - Do not use this unit for potable (drinking) water sanitation.

Swimming pools and similar water vessels are simple to calculate. See table below. NOTE: All capacities are nominal. Multiple Ultra UV₂ units installed in parallel can be used for flow rates beyond those specified herein (see page 7).

Pool, Spa, Fountain, Water Feature And Water Fall Sizing Chart

Part Number	Minimum Flow Rate GPM / (m3/hr)	Maximum Flow Rate GPM / (m3/hr)	Max. Pool Volume 12 Hr. Turnover Gallons / (m3/hr)	Max. Pool Volume 8 Hr. Turnover Gallons / (m3/hr)	Minimum Operating Pressure psi / bar	Maximum Operating Pressure psi / bar
004-422-2025-00 (Hard Wired 120V/230V 1 Lamp) 004-422-2021-00 (Plug In 120V 1 Lamp)	10 / 2.27	46 / 10.4	33120 / 125.4	22080 / 83.6	5 / 0.345	50 / 3.45
004-422-2026-00 (Hard Wired 120V/230V 2 Lamps) 004-422-2022-00 (Plug In 120V 2 Lamps)	20 / 4.54	80 / 18.2	57600 / 218.0	38400 / 145.4	5 / 0.345	50 / 3.45
004-422-2027-00 (Hard Wired 120V/230V 3 Lamps) 004-422-2023-00 (Plug In 120V 3 Lamps)	*30 / 6.81	*130 / *29.5	93600 / 354.3	62400 / 236.2	5 / 0.345	50 / 3.45

*Header size should be 2½" or 3" and split to two 2" pipe headers at the inlet and outlet connections.

Installation

NOTICE - The first step in starting your installation is to inspect the Ultra UV2 unit for damage, paying close attention to the quartz tube.

Locating the Ultra UV2 Unit

Your unit can be installed indoors or outdoors. When considering the location for your Ultra UV2 unit, keep it close to your power source. Check the silver product label for the voltage of the unit. The Ultra UV2 unit will need to be powered from either a 120V/15A/50/60Hz or 230 V/15A/50/60Hz electrical circuit (which **MUST** match the unit power requirement noted on the silver product label on the Ultra UV2 unit as shown below). **DO NOT CONNECT TO ELECTRICAL POWER NOT SPECIFIED FOR YOUR UNIT.** Plug in units must be installed on a GFCI outlet. The GFCI must be outdoor rated if installed outdoors. Hard Wired Ultra UV2 units can be wired for 120V or 230V.

⚠ WARNING - DO NOT CUT OFF corded plug from the 120V Ultra UV2 units and hard wire it. This does not meet the U.L. installation method and voids the U.L. listing.

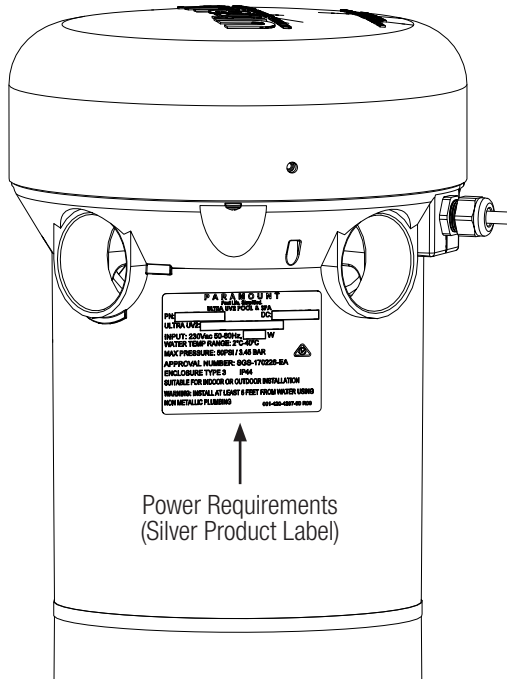



Paramount®

Mounting the UV Unit on a Solid Base

Before you make the permanent plumbing connections, be sure the Ultra UV2 unit is on a solid level base with aligned plumbing connections. Make sure there is ample space above the unit for lamp replacement. After making your plumbing connections, anchor the unit to the base using the four ¼" mounting holes. **FAILURE TO PROPERLY SECURE THE UNIT MAY CAUSE NOISE OR VIBRATION.**

Installing Inlet/Outlet Unions

The Ultra UV2 unit comes with female socket glue-in inlets and outlet openings. **ABS to PVC multipurpose glue** and appropriate primer must be used to glue fittings into the Ultra UV2 body. The 4 outlets (top) and 4 inlets (bottom) provide the most versatile piping alternatives for the installer. 1 and 2 lamp units include two unions for plumbing inlet & outlet pipes. 3 lamp units include four unions for plumbing inlet and outlet pipes as shown on page 7.

NOTE: To install the union onto the Ultra UV2 unit, glue and insert the union spigot end into the inlet and outlet opening selected. Then, using the six plugs provided, glue the plugs into the remaining unused plumbing openings. Hand tightening the union nuts until snug is sufficient. **DO NOT OVER TIGHTEN.** Over tightening may break the molded plastic parts of the union.

NOTICE - 24 hour cure time is required before pressure can be applied to the Ultra UV2 unit.

Plumbing the Ultra UV2 Unit

All plumbing methods are illustrated with and without the bypass option. Your Ultra UV2 unit will need to be plumbed into the circulation system. The Ultra UV2 unit must be installed directly after the filter. Installing a bypass is not recommended (see page 6).

NOTICE - An improperly used bypass installation may not meet the minimum required flow rate and could potentially damage the Ultra UV2 unit.

NOTICE - Do not plumb the Ultra UV2 with a bypass unless absolutely needed. Failure to follow the instructions can result in damage to the Ultra UV2 that is not covered by the warranty.

⚠ DANGER - Turn off the power at the main source before disconnecting or connecting the Ultra UV2.

NOTICE - Using the supplied unions is strongly recommended.

Gluing Piping to the UV Unit

Two Inlet/Outlet unions are supplied on 1 & 2 lamp units and 4 unions are supplied on 3 lamp units. Your PVC supply piping should be glued into the union tail pieces using an appropriate primer and ABS to PVC cement. Inlet piping should be supported and should not rest solely upon the unions, to avoid stressing or breaking the unions. Allow the glue to set following the glue manufacturers recommendations before pressure testing. A minimum of 24 hours is recommended. Maximum test pressure for the Ultra UV2 is 50 PSI / 3.45 BAR as noted on the silver label on the unit. If local codes require the pressure test to be higher than the max operating pressure on the silver label, use the

bypass (if the unit is plumbed with a bypass) to ensure that the Ultra UV2 is at or below the max operating pressure.

A. Plumbing the Ultra UV2 Unit with Optional Bypass Valve

Installing a bypass is not recommended and should only be considered:

1. To allow for removal of the UV unit for winterization, servicing, repairs, or replacement, while still allowing water to flow through the system. Before bypassing the Ultra UV2 for removal, turn off all pumps and allow the pool system's pressure to drop to zero.
2. If system pressure testing above 50 psi is required (max Ultra UV2 pressure is 50 psi / 3.45 bar).

B. Installing Optional Flow Switch if the Top of the Unit is Below Water Level

The pressure switch can always be on if the Ultra UV2 unit is plumbed below water level. To prevent damage to the unit and its surroundings, an optional flow switch must be installed. If the Ultra UV2 unit is plumbed on a bypass, the optional 2 inch Flow Switch (part #004-402-0010-00 for 230V or part #004-421-3824-00 for 120V), must be on the outlet side of the Ultra UV2 unit and plumbed after the two way valve and before the tee into the return line. Please refer to the instructions supplied with the flow switch for plumbing and wiring.

Typical Plumbing With and Without Bypass

The inlet(s) is at the bottom of the unit and the outlet(s) at the top. The maximum operating pressure for the Ultra UV2 is 50 PSI / 3.45 BAR. The minimum operating pressure is 5 PSI / .345 BAR. Please refer to the silver label on the unit for maximum operating pressure.

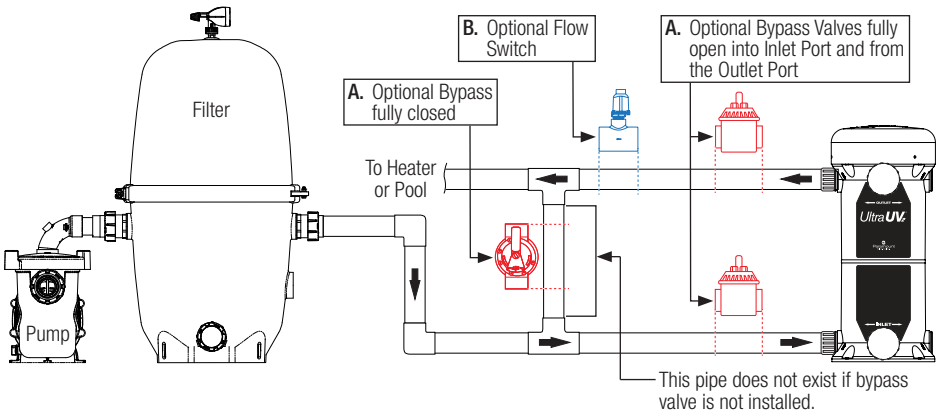

Parallel Plumbing With and Without Bypass

Plumbing Ultra UV2 units in parallel for large bodies of water with high flow rates.

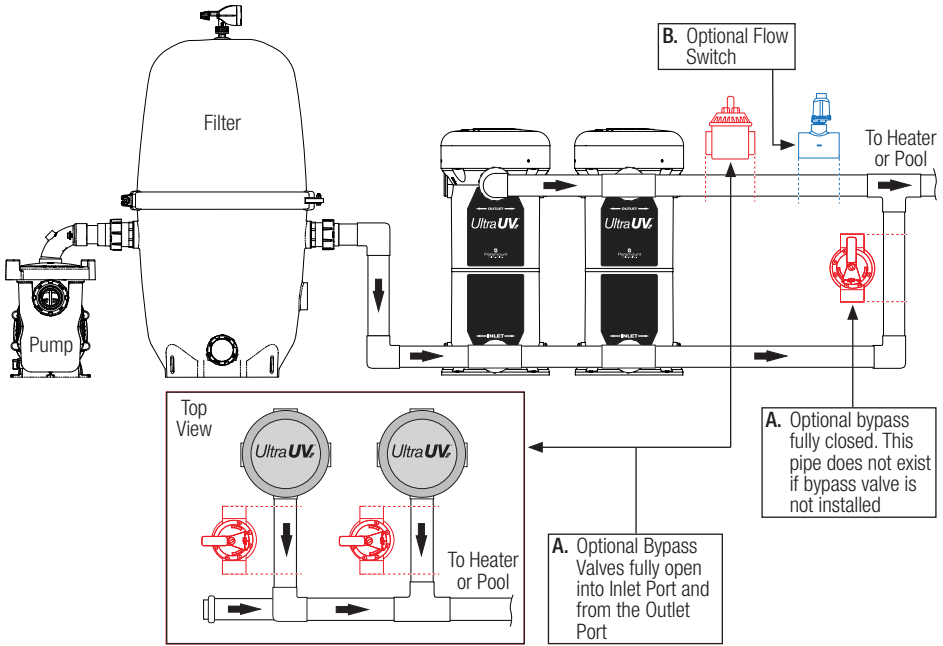

Multiple Port Plumbing for 3 Lamp Units With and Without Bypass

Ultra UV2 3 lamp units require 2 inlets and 2 outlets be plumbed.

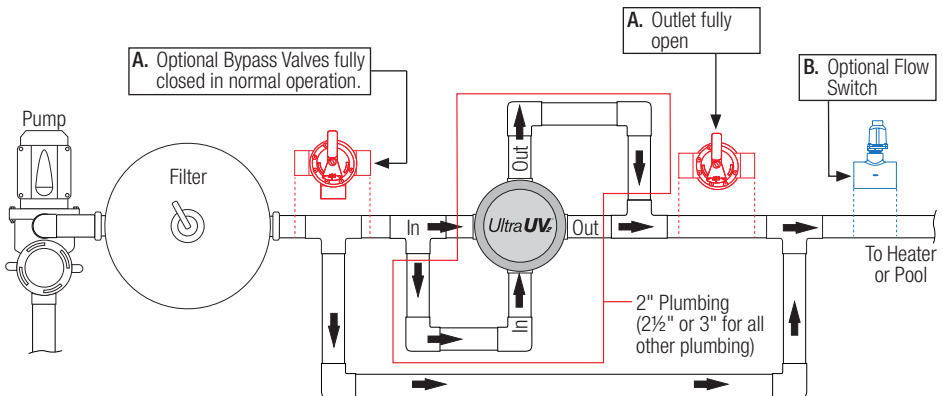



Electrical Wiring

⚠ WARNING - Grounding. This product must be grounded. If it should malfunction or break down, grounding provides a path of least resistance for electrical current to reduce the risk of electric shock. Plug in models are equipped with a cord having an equipment-grounding conductor and a grounding plug. The plug must be plugged into an appropriate outlet that is properly installed and grounded in accordance with all local codes and ordinances.

⚠ DANGER - Improper connection of the equipment-grounding conductor can result in a risk of electrocution. Check with a qualified electrician or service personnel if you are in doubt as to whether the outlet is properly grounded. Do not modify the plug provided with the product - if it will not fit the outlet, have a proper outlet installed by a qualified electrician. Do not use any type of adapter with the product.

⚠ DANGER - Ground Fault Circuit Interrupter Protection. To comply with the national electrical code (NFPA 70) and to provide additional protection from the risk of electric shock, this unit should only be connected to a receptacle that is protected by a ground circuit interrupter (GFCI).

The electrical power rating for your Ultra UV2 unit is shown on the silver label located on the outside of the unit (shown in the image on page 4). Make sure the supplied power meets the electrical requirements. Connecting any power than that listed on the rating label will damage the unit and will VOID your limited warranty.

Plug In 120V 50/60Hz Ultra UV2 Units

1. A properly rated ground fault circuit interrupter must be installed in the electrical outlet serving the Ultra UV2. Check your local and national electrical codes.
2. Connect the included 3-plug grounded NEMA plug to an outlet protected by a ground fault circuit interrupter.
3. Connect the electrical bonding per instructions shown on the following page.

⚠ WARNING - Do not cut the plug off the electrical cord and connect it directly to a 120V power source. If this is done your warranty is voided and the U.L. listing is invalidated.

⚠ WARNING - Should the electrical cord become frayed or damaged in the future, unplug it from the power receptacle and replace it immediately.

Hard Wired 120/230V 50/60Hz Ultra UV2 Units

NOTICE - Have this work done by a licensed electrical technician.

1. Install the conduit into the seal-tight connector.
2. Lift the grommet from the mounting plate and feed the black, white, and green wires (Fig. 2). Use the supplied tube of silicone and cover the wires at the junction of the conduit connector (Fig. 3). Reinstall the grommet to the mounting plate.
3. Attach one power leg (most likely black) to the upper right position of the terminal block. Attach one power/neutral leg (most likely white) to the lower right position of the terminal block (Fig. 4). NOTE: The terminal block is sized to accept a spade terminal for 18-22AWG wire.
4. Cut the ground wire to length and attach an 18-22 AWG ring terminal. Remove the nut from the left ground post. Place the ring terminal over the ground post. Reattach the nut. See Fig. 5.

⚠ WARNING - Failure to silicone the wires in the connector could result in water from a leak in the unit leaking down the conduit and causing non-warranted damage to other components.

Electrical Bonding

Locate the bonding lug next to the power cable (Fig. 1). To reduce the risk of electric shock, this terminal must be connected to the bonding lug in the electrical supply service panel with a continuous copper wire equivalent in size to the circuit conductors supplying this equipment. To reduce the risk of electric shock, connect the local common bond grid in the area of the pool or spa to this terminal with an insulated or bare copper conductor per national and local codes. The electrical installation is now complete.

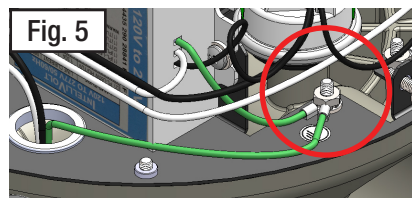
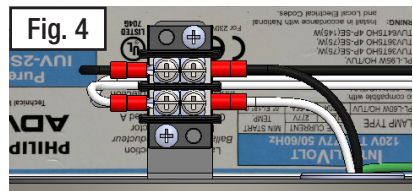
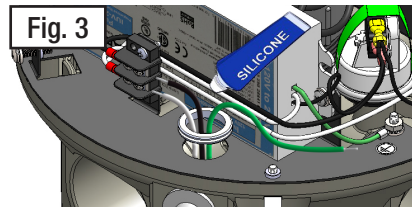
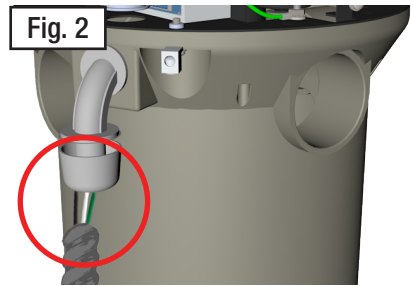
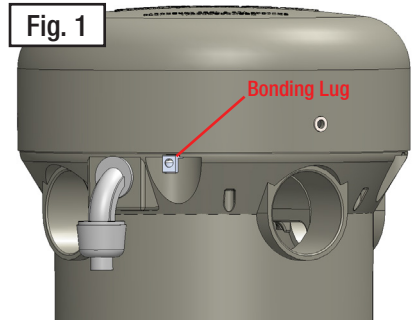

System Start-Up

NOTICE - Do not connect the pressure switch until the pool is operational!

Pressure Switch

The Ultra UV2 unit is equipped with a pressure switch that does not allow the UV lamp(s) inside the unit to light unless there is at least 2 PSI (0.137 BAR) inside the Ultra UV2 reactor chamber. This will ensure that the lamp(s) will illuminate when the Ultra UV2 unit has water flowing through the reactor.

Connecting Pressure Switch

Disconnect power to the Ultra UV2 unit. Remove the cover (Fig. 6) and locate the pressure switch and the loose lead with the female spade connector (Fig. 7). Connect the female spade connector to the male top spade connector on the pressure switch (Fig. 8). Replace the cover and restore power to the unit. Turn on the pump and when the flow switch is activated, the unit should be on and the lamps illuminated. Look at the "Glow Ring" in the center of the unit to check that all lamps are lit. If the lamps are not lit, please check the following:

1. Adjust the system valves to ensure adequate flow through the Ultra UV2 unit.
2. Increase the pump speed to produce enough pressure to energize the Ultra UV2 unit.
3. Refer to the troubleshooting section of this manual (page 17).

NOTICE - The filter gauge DOES NOT indicate the pressure in the UV unit.

⚠ WARNING - Do not look directly at the lamps. Serious injury will occur.

Water Chemical Balance

If you have installed your Ultra UV2 unit on any water vessel other than fish ponds or ponds with live plants, it is important that you check and adjust the chemical balance of the water.

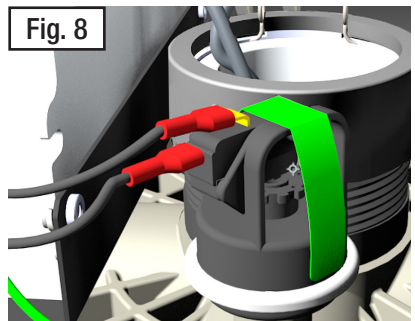
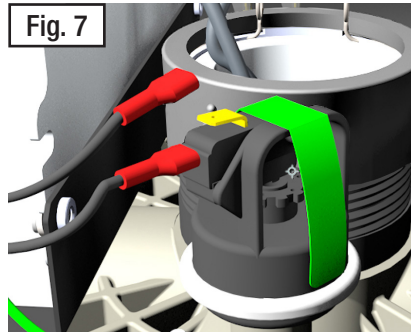
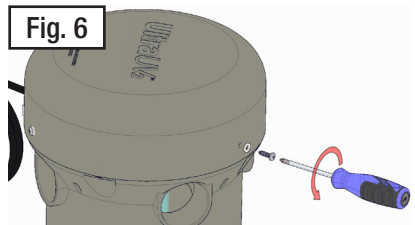

Normal Operation

Configuration for Ultra UV2 units installed with bypass. During normal operation, the inlet valve #2 and outlet valve #3 should be completely open and the bypass valve #1 should be completely closed. This instruction applies to all systems with a single speed or with a variable speed pump. This type of damage is not covered under the factory warranty. Any partial opening of the bypass valve can drop the flow rate below the required minimum and cause damage to the Ultra UV2 unit.

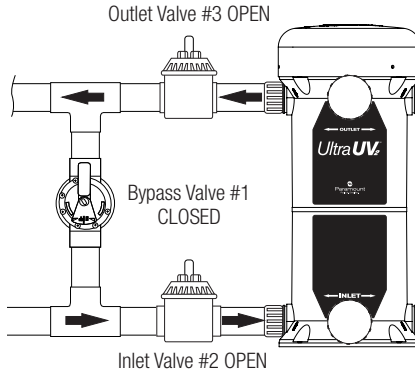

Winterize / Service Operation

Configuration for Ultra UV2 units installed with bypass. Bypass operation is used for winterization or servicing the Ultra UV2 unit. The bypass valve #1 should be fully open and the inlet valve #2 and the outlet valve #3 should be completely closed.

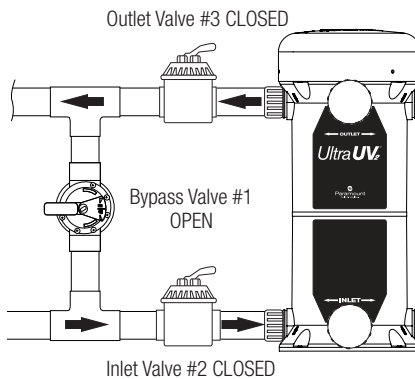

Maintenance

Winterization of Your Ultra UV2 Unit

If you are in a sub freezing climate, you must winterize the Ultra UV2 using either option #1 or #2. Failure to do so will cause damage to the unit, which is not covered under the warranty.

Option #1 - Removing the unit for the winter: Turn off the power to the unit. Disconnect the unions on the plumbing to ensure that the unit is completely drained. Now, with the power off, disconnect the unit from its power source and place the drained unit in a safe place that has a sustained temperature above freezing. Reinstall after the temperatures are considerably above freezing.

Option #2 - Leaving the unit in place for the winter: Turn off the power to the unit. Disconnect the unions on the plumbing to ensure that the unit is completely drained. There is a cup in the bottom of your unit that the quartz tube nests in. This cup (shown on the right) does not drain completely. To remove the water from this cup you must first remove the lamp array and quartz tube. Turn the unit on its side with the unions facing down until all of the water has drained. Reconnect the unit, the quartz tube, lamps, and cover. You may store the lamps and quartz tube in a safe place.

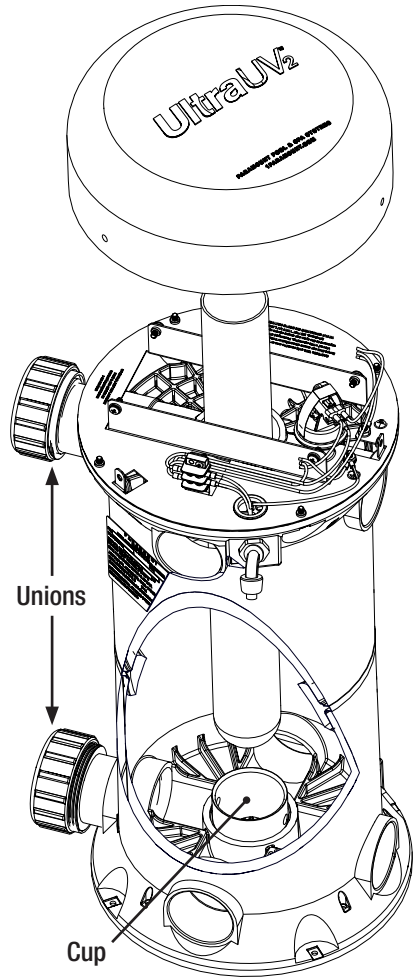



Paramount

Quartz Tube Maintenance

NOTICE - The quartz tube requires cleaning every 6 months to ensure optimum performance.

1. Turn off all power to the Ultra UV2 unit and all other pool equipment. Unplug the unit from its power receptacle or turn OFF the circuit breaker that is the Ultra UV2's power source. Allow at least 15 minutes for the lamp(s) in the unit to cool before proceeding to step 2.

⚠ DANGER - Never remove the electrical enclosure cover without first disconnecting the power (power source) for the Ultra UV2 unit. Never remove the Ultra UV2 unit's cover without turning off the pump.

2. Remove the three screws that secure the plastic cover then remove it.

⚠ WARNING - Before removing lamps, you must wear protective rubber gloves and safety eyewear. Do not handle a hot lamp or serious burns will occur.

NOTICE - Do not touch the glass part of the lamp as body oils will create hot spots & greatly shorten lamp life.

3. Disconnect all lamps by pressing the release tabs on connectors and gently pulling apart (Fig. 9).
4. Remove the spring clip (Fig. 10). Carefully lift the old lamp assembly, including lamp holder, from the quartz tube (Fig. 11). Do not pull excessively on the lamp wires. Set aside the lamp assembly in a safe area to avoid breaking or chipping.
5. Turning counter-clockwise, unscrew and remove the round aluminum sealing nut (Fig. 12).
6. Carefully lift the aluminum compression washer from the top of the quartz tube making sure not to lose the black gasket that cushions the edge of the quartz tube (Fig. 13).
7. Grip quartz tube with both thumbs inside and pull up (Fig. 14). Once the O-ring breaks free, the quartz tube should lift out easily.

NOTICE - The quartz tube is fragile, be sure to handle it with proper care and do not set it down on a hard surface. Do not use abrasive cleaners or pads.

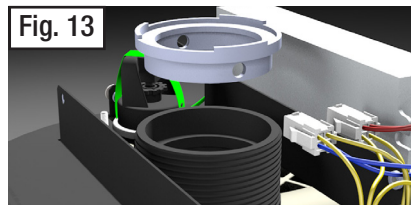
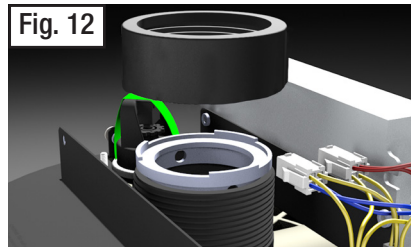
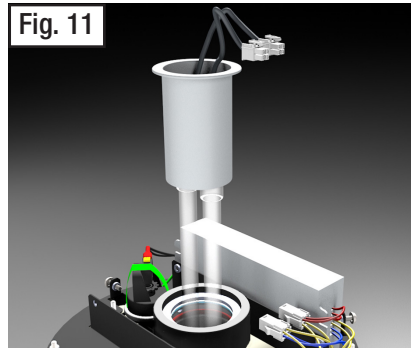
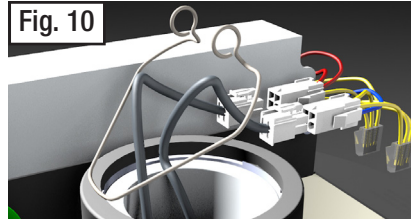
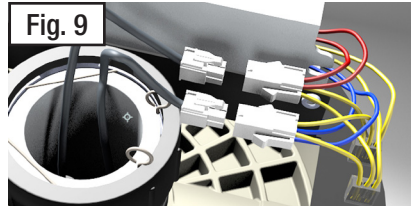

8. Using protective rubber gloves and eye wear. To clean the outside of the quartz tube, use shower/tub cleaner, CLR or equivalent, or a solution of white vinegar and water. Remove the O-ring from the quartz tube. If the inside of the quartz tube is moist or needs cleaning, use the same cleaning method. The quartz tube must be completely dried and clear of residue especially near the surface where the O-ring rests before reassembly.
9. Inspect the quartz tube carefully for any cracks or chips and replace the quartz tube if any are found.

NOTICE - Do not use any other O-ring at any time for sealing the quartz tube. Doing so can result in a leak and possible damage to your UV unit. The O-ring must be replaced after cleaning the quartz tube. See page 21 for part number.

10. All components must be completely dry and clean, especially near the surface where the O-ring rests. Never use any type of lube or sealing agent. To reinstall the quartz tube, place a new O-ring 2 inches from the top of the outside of the quartz tube (Fig. 15). Gently lower the quartz tube into the unit until the O-ring makes contact with the top of the black threaded sealing sleeve. Note: Use a Paramount O-ring seal only.
11. Place the aluminum compression washer and gasket on the quartz tube (Fig. 16). Press down on the aluminum compression washer with an even steady pressure. This will roll the O-ring into the area between the inside of the black threaded sleeve and the quartz tube. Lift aluminum washer and check to make sure it is seated evenly around the circumference of the quartz tube (Fig. 17). Replace aluminum washer then screw on the quartz sealing aluminum nut to hand tight plus $\frac{1}{2}$ turn.
12. Turn power on to the Ultra UV2 unit. Turn pump on to check for leaks. Confirm that there are no leaks, then turn off pump and power off to the unit. Reinstall lamps, spring clip and connect to ballast(s). Reattach cover. Turn power on to unit and turn pump on.

⚠ CAUTION - Do not stand over the unit when it is under pressure or when the pump is on.

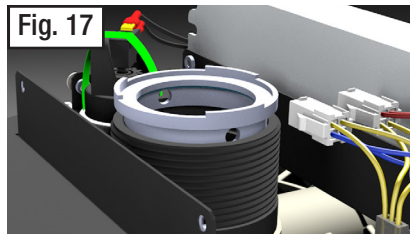
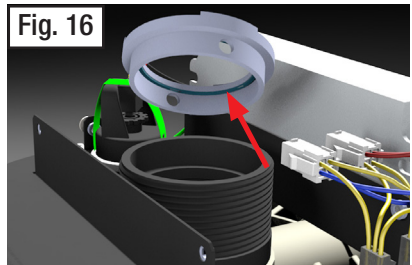
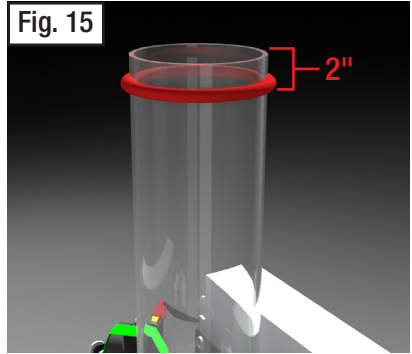
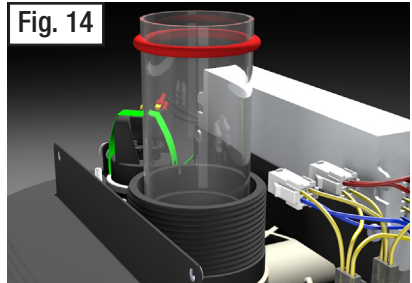

Scheduled Uv Lamp(s) Replacement

The UV lamp(s) have a useful life of approximately 2½ years and should be replaced at that time. Even though the lamp(s) may be glowing after 2½ years of operation, they have reached the end of their useful life.

1. Turn off all power to the Ultra UV2 unit and all other pool equipment. Unplug the unit from its power receptacle or turn OFF the circuit breaker that is the Ultra UV2's power source. Before proceeding to step 2, allow at least 15 minutes for the lamp(s) in the unit to cool.

⚠ DANGER - Never remove the electrical enclosure cover without first disconnecting the power (power source) for the Ultra UV2 unit. Never remove the Ultra UV2 unit's cover without turning off the pump.

2. Remove the three screws that secure the plastic cover then remove.

⚠ WARNING - Before removing lamps you must wear protective rubber gloves and safety eye wear. Do not handle a hot lamp or serious burns will occur.

NOTICE - Do not touch the glass part of the lamp as body oils will create hot spots & greatly shorten lamp life.

3. Disconnect all lamps by pressing the release tabs on connectors and gently pulling apart Fig. 9 on page 13.
4. Remove the spring clip Fig. 10 on page 13. Carefully lift the lamp assembly, including lamp holder from the quartz tube Fig. 11 on page 13. Do not pull excessively on the lamp wires.
5. Carefully remove new lamp assembly from box. Insert lamp(s) into lamp holder. Lamp(s) must be aligned and seated securely in the lamp holder. Roll the black o-ring(s) up onto the ceramic end

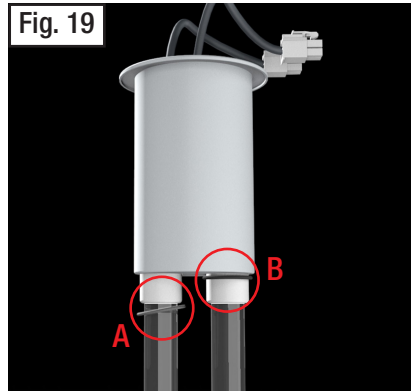



of lamp from position A to B (Fig. 19). Gently insert lamps into the lower lamp retainer (Fig. 18) and lower lamp assembly into unit.

6. Re-install the spring clip and re-attach the lamp connector(s) to the ballast (Fig. 10). Note: The lamp connector(s) can only be installed one way.
7. Discard lamp(s) appropriately. Visit www.lamprecycle.org for instructions on disposal.

FAQs

Is the Ultra UV2 unit designed for use in salt water applications?

Yes. Paramount's Ultra UV2 units are fully compatible with all salt water environments. The quartz tube could require more frequent cleaning in a salt water environment.

Do I need to turn my Ultra UV2 unit off when I backwash my filter?

No. The unit does not energize because it is not under pressure during backwashing. If you have a cartridge filter, turn off the power prior to opening the filter.

What would shorten the lamp life of the Ultra UV2 unit?

Multiple daily cycles can shorten lamp life. Oils from touching the lamps with bare hands.

Can the Ultra UV2 unit be mounted horizontally?

No, vertical mounting is required to maintain the weatherproof integrity of the electrical enclosure cover.

Can the Ultra UV2 unit be installed below the vessel's waterline?

Yes. But if the unit is below water level you must install a flow switch. See pages 6 and 7.

Can multiple units be used together for larger systems?

Yes, you can pipe any number of Ultra UV2 units in parallel. See page 7.

Must I use a GFCI (Ground Fault Circuit Interrupter) with my UV unit?

Yes. But consult your local and national electrical codes as there could be other requirements. You must use a G.F.C.I. receptacle on the 120V plug in unit. When using a 230V hard wired unit, use a 15A G.F.C.I. breaker.



Paramount®

Troubleshooting

Identifying and Correcting System Problems

The list below will help guide you through any problems you may have at the time of initial installation or in the future. For additional assistance, contact your supplier or Paramount technical support.

The UV Lamp(s) Will Not Illuminate

If this occurs upon initial start-up, the problem could be caused by a number of issues:

1. Not enough system back pressure to activate the pressure switch.
 - a. Make sure the system filter and all debris baskets are clean.
 - b. Verify that the Ultra UV2 unit is operating at a minimum of 2psi, which is required to activate the pressure switch. Please note that the filter gauge does not indicate the pressure in the UV unit.
 - c. If the operating pressure of the Ultra UV2 unit is below 2psi: Restrict flow in the return manifold to create enough back pressure to activate the pressure switch. If using a variable speed or multi speed pump, be sure that the high speed setting does not create excessive system back pressure once you've adjusted the flow. Alternatively you may need to increase the low speed setting of the pump to achieve the minimum required pressure.
2. All Ultra UV2 units come with the pressure switch disabled. To ensure the pressure switch is properly enabled, refer to page 10.
3. Check if the pressure switch is functioning properly. With at least 2psi pressure at the vessel, see if the switch is open. The pressure switch can be checked by turning off the power to the unit while maintaining a pressure of 2psi or higher in the unit. With the power off and the unit under pressure, disconnect the 2 leads to the pressure switch and check for continuity across the 2 pressure switch terminals. If you have continuity, the pressure switch is good (closed under pressure). Relieve the pressure from the unit and check the continuity between the 2 terminals of the pressure switch. If there is no continuity without pressure in the vessel, the pressure switch is good in the open position. If the pressure switch checks good in both the open and closed positions, proceed to checking the lamps.
4. Check if the UV lamp(s) has/have become disconnected from the lamp connector(s). Disconnect the power servicing the Ultra UV2 unit, remove the cover and confirm the lamp connector(s) is/are firmly locked together. At the same time, check all exposed wires for a possible loose connection. Reestablish power ONLY after the cover has been re-installed on the Ultra UV2 unit.
5. Verify that the electrical cord is plugged into an energized electrical outlet or properly connected to the power source. Test the electrical outlet. You should confirm the availability of the same power as indicated on the electrical label on your Ultra UV2 unit.

The UV Lamp(s) Is/Are No Longer On

If this occurs after the unit has been operating successfully for a period of time:

1. One or more lamps have failed. Replace the UV lamp(s).
2. A ballast has failed. Contact your supplier or Paramount for assistance in obtaining a new ballast.
3. Verify that the electrical outlet is supplying the proper voltage and that the cord is securely plugged into the outlet or connected to the power source.



Paramount

4. Verify that the GFCI has not tripped. To verify the operating state of the GFCI, trip the GFCI manually and reset it manually. The GFCI should reset. If it does not, it indicates a fault to ground in the electrical circuit or the Ultra UV2 unit itself. Contact your supplier for assistance.
5. The ballasts have internal protection that will power down the lamps in the case of an electrical event. Power down the unit for 5 minutes. This will reset the internal protection. When the power is returned, the internal protection is reset.

The Water is Green

1. Check the lamp(s) to make sure all lamps in your system are ON (by viewing the lamp(s) through the clear viewing band on the center of the reactor. If all lamps are not ON, follow the procedures on page 17 regarding the UV lamp not lighting.
2. Run your unit longer. If your unit is operating on a time clock, run the circulation pump longer to allow the Ultra UV2 unit to function fully.
3. Clean the quartz tube(s).
4. Replace the UV lamp(s) nearing the 2½ year useful lamp life. After 2½ years of operation, the UV lamp(s) are only 80% as effective as when new. This is normal for all long life low-pressure type UV lamps, which are the longest useful life lamps available for this type of application.
5. If your Ultra UV2 unit is installed on a swimming pool, shock the pool with the sanitizing chemical you normally use and balance the pool water as per your chemical manufacturer's specifications.
6. Your unit is not sized for the flow and duration specific to your pool.

The GFCI Has Tripped

The GFCI will protect the Ultra UV2 unit and any other equipment on the same electrical circuit from any fault to ground, the same as the electrical breaker protects the total electrical circuit from a short. When the GFCI trips, it is an indication that there is an electrical problem that must be corrected to provide a safe operating environment for your installation. Follow the instructions of the GFCI manufacturer for more information on correcting the issue if the problem is with the GFCI.

1. If you suspect that the problem is with the Ultra UV2 unit, disconnect the Ultra UV2 unit from the electrical receptacle. Reset the GFCI at the breaker panel or at the receptacle. If the GFCI does not reset, have the GFCI replaced by a licensed electrician. If the GFCI does reset, first run the circulation pump, and if no GFCI trip is encountered, plug the Ultra UV2 unit into the electrical receptacle and make sure the pump is ON. If the GFCI trips, it is an indication that there is a ground fault inside the Ultra UV2 unit. Follow the instructions previously given for opening the electrical enclosure cover and inspecting the Ultra UV2 unit. Call a qualified technician.
2. If water is present inside the electrical enclosure cover, it will trip the GFCI. Following instructions given on page 13 to remove the quartz tube(s), inspect for quartz tube cracks or breakage or for a bad quartz tube seal. Replace the quartz tube if it is cracked or broken. If not, reseal it.
3. If the Ultra UV2 unit trips when performing the test noted in Step 1 above, you can check to determine if a UV lamp is the GFCI trip cause by unplugging the individual lamp from the lamp connector, then place the electrical enclosure cover back on the Ultra UV2 unit and power up the circulation pump. If the GFCI does not reset, then the problem is either with the remaining lamp(s) or with a ballast. Remove all the lamp connectors and reset the GFCI after replacing the electrical enclosure. If the GFCI still trips, unplug all ballasts. If the GFCI resets, then plug in first one ballast, and if your unit has two ballasts, then the second ballast after the first ballast has been tested. If either ballast trips the GFCI, then replace that ballast. Refer to page 21 for the



Paramount®

proper ballast part number. Reset the GFCI and if it does not trip, attach the electrical plug to a UV lamp (one at a time if multiple lamps are present in your Ultra UV2 unit). If it trips with the lamp lit, it indicates that a UV lamp is causing the fault to ground. Replace the UV lamp.

The Ultra UV2 Unit Makes Noise When Operating

This is an indication of the Ultra UV2 unit not being properly attached to a firm mounting base of concrete using bolts (not supplied) placed through the mounting holes in the Ultra UV2 unit base. Attach the Ultra UV2 unit correctly to a firm base as described in page 5.

Water is Dripping from the Electrical Enclosure Cover

Water exiting the unit through the electrical enclosure cover can be attributed to either (a) a bad quartz tube seal, or (b) a broken or cracked quartz tube. Check the quartz tube seal and quartz tube as instructed on page 13.

Specification Notice

Due to Paramount's commitment to continuous product improvement, all product descriptions or specifications noted herein are subject to change without notice.

Limited Warranty

Ultra UV2 water treatment devices are covered under a 2 year Limited Warranty. To view warranty, go to: www.1paramount.com/downloads/warranties/UltraUV2Warranty.pdf.

PROPER INSTALLATION OF THE ULTRA UV2 IS ESSENTIAL. FOR QUESTIONS, PLEASE CALL PARAMOUNT AT 1.800.621.5886 OR CONTACT YOUR REGIONAL REPRESENTATIVE. PLEASE FOLLOW ALL LOCAL CODES AND POOL SAFETY GUIDELINES.

Head Loss Curves

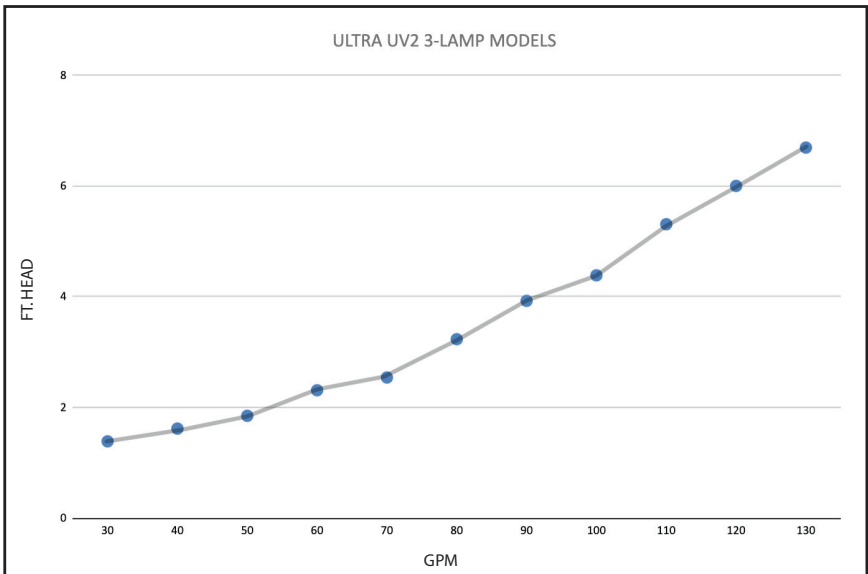
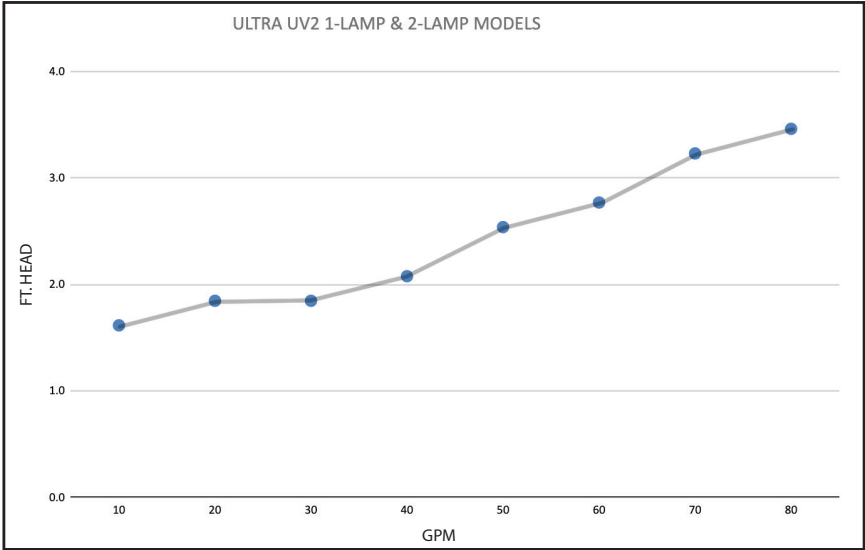

Replacement Parts

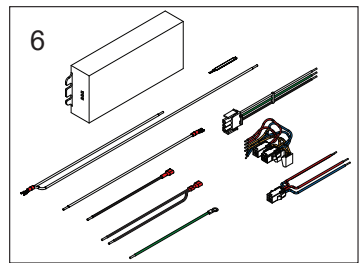
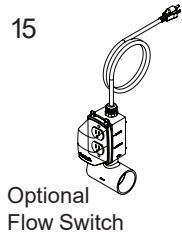
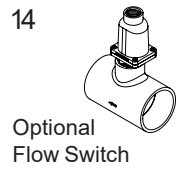
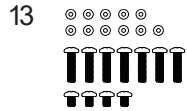
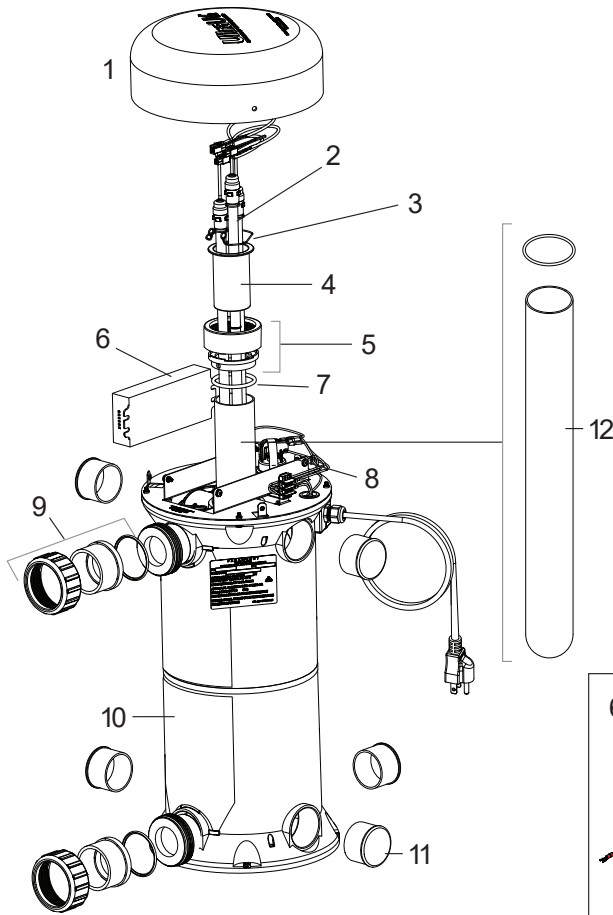

Ultra UV2 Replacement Part Numbers		
	Paramount Part #	Description
1	005-422-2009-11	Cover
2	005-422-9017-00	UV Lamp
3		Spring Clip
4		UV Lamp Holder
5	005-422-5102-00	Quartz Tube Sealing Assembly
6	005-422-9030-00	Universal Ballast Replacement Kit
7	005-422-5103-00	Quartz Tube Seal O-ring, 3-Pack
8	005-422-2009-10	Pressure Switch
9	005-422-2009-06	2" Union Kits
10	005-422-3000-00	Replacement Housing
11	005-422-2009-08	2" Blanking Plug
12	005-422-2009-09	Quartz Tube with Seal Kit
13	005-422-2009-04	Screw Kits
14	004-402-0010-00	Flow Switch 1½" or 2" (Optional)
15	004-421-3824-00	Plug In, 120V Flow Switch for 2" Pipe (Optional)

For further information or consumer
technical support, visit our website at
www.1Paramount.com



Ultra UV2 is a registered trademark
of Hayward Industries, Inc. © 2024 Hayward Industries, Inc.

All other trademarks not owned by Hayward are the property of their respective owners. Hayward is not in any way
affiliated with or endorsed by those third parties. For patent information, refer to www.hayward.com/patents.

USE ONLY PARAMOUNT GENUINE REPLACEMENT PARTS